

CWDM 25 Gbps DFB Laser Chip

L-CT-ICXX-XX Series

Ver. : 2.5

Part Number: L-CT-ICXX-01

Product Description:

The LuxNet L-CT-ICXX-01 DFB laser chip is designed for high speed, high performance data communication and telecommunication applications. It is suitable for cooler-less application over a wide temperature range at speeds up to 25 Gbps.

Product Specifications:

Absolute Maximum Ratings

Parameter	Symbol	Unit	Min.	Max.	Note
Operating Temperature	T_{op}	°C	-5	75	
Storage Temperature	T_{stg}	°C	-40	100	
Die-Attach Temperature		°C		300	5 seconds max.
Maximum Power	P_o	mW		20	
Reverse Voltage	V_r	V		2	

Electro-Optical Characteristics ($T_a = 25^\circ\text{C}$, unless noted otherwise):

Parameter		Symbol	Unit	Min.	Typ.	Max.	Test Condition
Threshold Current		I_{th}	mA		6	10 25	$T_a=25^\circ\text{C}$ $T_a=75^\circ\text{C}$
Operating Voltage		V_{op}	V		1.2	1.5	$P_o=5\text{ mW}$
Slope Efficiency		η	W/A	0.2			$T_a=25^\circ\text{C}$
Peak Wavelength	L-CT-IC27-01	λ_p	nm	1264.5		1277.5	$P_o=5\text{ mW}$ $T_a=-5\sim 75^\circ\text{C}$
	L-CT-IC29-01			1284.5		1297.5	
	L-CT-IC31-01			1304.5		1317.5	
	L-CT-IC33-01			1324.5		1337.5	
	L-CT-IC35-01			1344.5		1357.5	
	L-CT-IC37-01			1364.5		1377.5	
Side Mode Suppression Ratio		SMSR	dB	35			$P_o=5\text{ mW}$
Beam Divergence Angle (//)		$\theta_{//}$	degree		25		FWHM @ $P_o=5\text{ mW}$
Beam Divergence Angle (\perp)		θ_{\perp}			40		
Rise Time		τ_r	ps		14		$I=30\text{ mA}$, 20-80 %
Fall Time		τ_f	ps		19		$I=30\text{ mA}$, 20-80 %
Bandwidth		f_{3dB}	GHz	18			$T_a=-5\sim 75^\circ\text{C}$
Relative Intensity Noise		RIN	dB/Hz		-130		$I=35\text{ mA}$

Note: T_a means ambient temperature.

Outline and Dimensions:

Dimension: (μm)
All dimensions are nominal

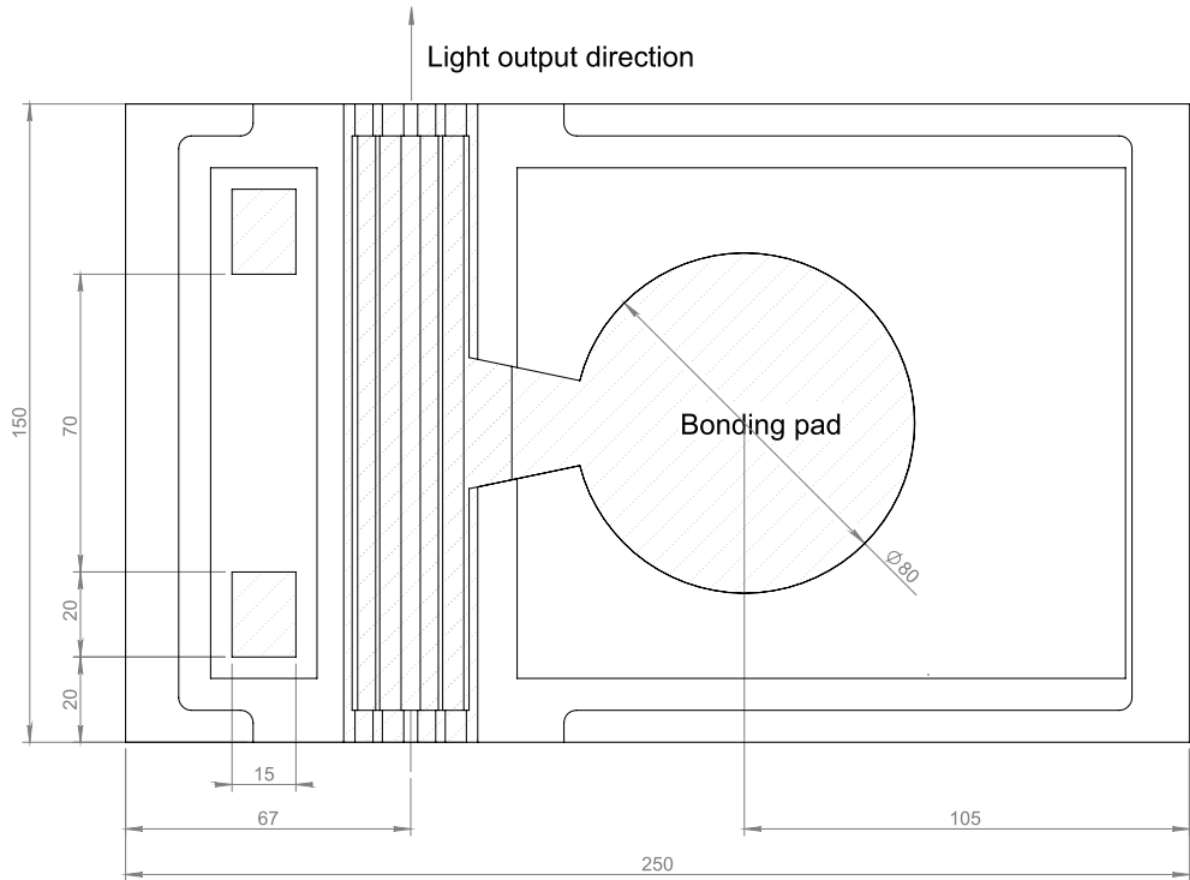

Fig. 1 Top view

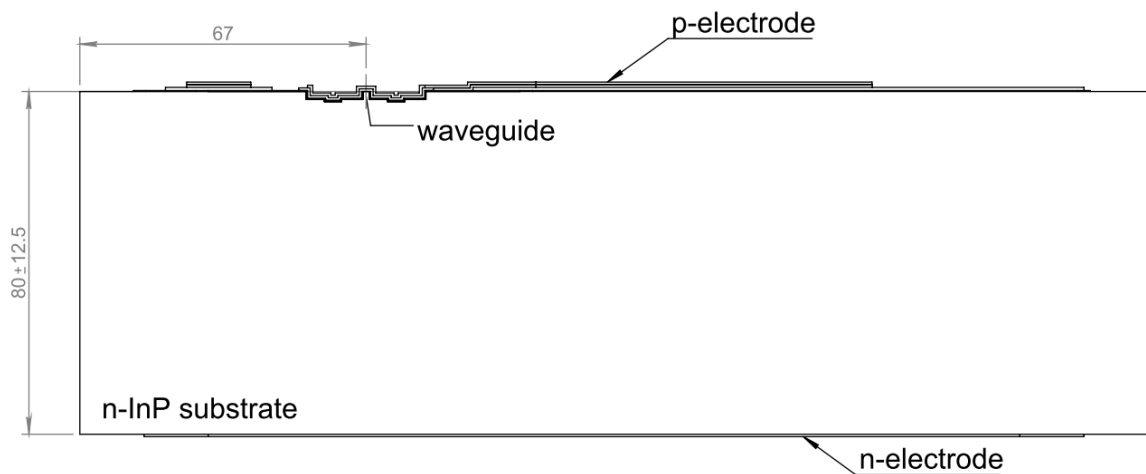

Fig. 2 Side view

Chip configuration:

1. Top contact: anode; Bottom contact: cathode.
2. Dimension: 250 μm (width) x 150 μm (cavity length) x 80 μm (thickness)
Tolerance: ± 12.5 μm (Thickness)
 ± 20 μm (Width, Length)